



Electrolux
PROFESSIONAL

**Modular Cooking Range Line
thermaline 80 - 800 mm Electric
Warming Cabinet with 2 doors, GN
conform, 1 Side (H2) - H=550**

ITEM # _____

MODEL # _____

NAME # _____

SIS # _____

AIA # _____



588315 (MA4HDAHOAO)

Electric warming cabinet,
with 2 doors, one-side
operated, GN - H2

Short Form Specification

Item No. _____

800 mm wide warming cabinet with 2 doors, constructed according to DIN 18860_2 with 70 mm recessed plinth. Internal frame for heavy duty sturdiness in 2 mm and 3 mm in 1.4301 (AISI 304). 2 mm top in 1.4301 (AISI 304). Flat surface construction, easily cle

Main Features

- All major components may be easily accessed from the front.
- THERMODUL connection system creates a seamless work top when units are connected to each other thus avoiding soil penetrating vital components and facilitating the removal of units in case of replacement or service.
- Unit constructed according to DIN 18860_2 with 70 mm recessed plinth.
- Temperature in the cupboard can be set through a thermostat to suit different requirements. The maximum temperature is 110° C.
- Unit can be installed below modular top appliances, designed to keep plates warm.

Construction

- IPX5 water resistance certification.
- 2 mm top in 1.4301 (AISI 304).
- Flat surface construction with minimal hidden areas to easily clean all surfaces
- Storage space in the base of the appliance accepts GN1/1 containers.
- Internal frame for heavy duty sturdiness in stainless steel.

Optional Accessories

- Stainless steel side panel (12mm), 800x800mm, freestanding PNC 912508
- Stainless steel front kicking strip, 800mm width PNC 912598
- Stainless steel side kicking strips left and right, freestanding, 800mm width PNC 912619
- Stainless steel side kicking strips left and right, wall mounted, 800mm width PNC 912622
- Stainless steel side kicking strips left and right, back-to-back, 1600mm width PNC 912625
- Stainless steel plinth, against wall, 800mm width PNC 912806
- Stainless steel plinth, freestanding, 800mm width PNC 912825
- Stainless steel panel (12mm) 800x800mm, against wall, left side PNC 913094
- Stainless steel panel (12mm) 800x800mm, flush-fitting, against wall, right side PNC 913098
- Back panel, 800x550mm, for bases and units, one-side operated PNC 913182
- Stainless steel side panel, left, h=800 PNC 913216
- Stainless steel side panel, right, h=800 PNC 913217

APPROVAL: _____



Experience the Excellence
www.electroluxprofessional.com

- - NOT TRANSLATED - PNC 913234
- - NOT TRANSLATED - PNC 913244
- - NOT TRANSLATED - PNC 913257
- - NOT TRANSLATED - PNC 913264
- - NOT TRANSLATED - PNC 913266
- - NOT TRANSLATED - PNC 913273
- - NOT TRANSLATED - PNC 913274
- - NOT TRANSLATED - PNC 913281
- STAINLESS STEEL DIVIDING PANEL
800X800MM LEFT/RIGHT PNC 913669
- ELECTRIC MAINSWITCH 25A 4mm²
NM FOR MODULAR H800 ELECTRIC
UNITS (FACTORY FITTED) PNC 913676
- - NOT TRANSLATED - PNC 913685

Front

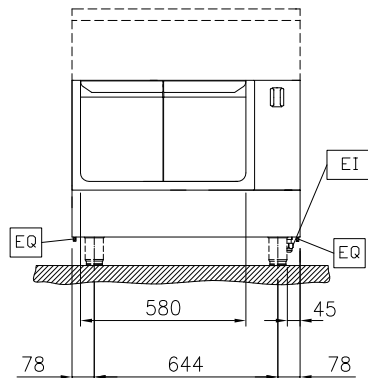

Side

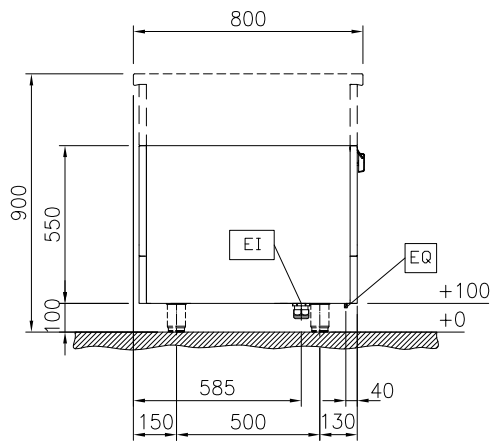

EI = Electrical inlet (power)

Top

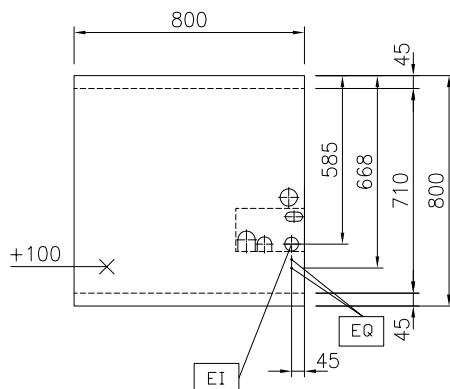

Key Information:

External dimensions, Width:	
588315 (MA4HDAHOAO)	800 mm
External dimensions, Depth:	800 mm
External dimensions, Height:	550 mm
Cupboard Cavity Dimensions (width):	580 mm
Cupboard Cavity Dimensions (height):	330 mm
Cupboard Cavity Dimensions (depth):	715 mm
Cabinet temperature range:	30-110 °C
Net weight:	30 kg

Sustainability

Current consumption:	5 Amps
----------------------	--------